

BLWRPG17 Series - Brushless DC Planetary Gearmotors



FEATURES

- 42mm Motor and Economy Gearbox
- Long Life - Over 3,000 Hour Operation
- Many Gear Ratios Available from 3.6 - 212
- Efficiency Up to 90%
- Backlash Less than 3°
- Can be Customized for
 - The Speed You are Running
 - The Winding Current You Need
 - The Shaft Options You Want
- CE Certified and RoHS Compliant



DESCRIPTION

The BLWRPG17 Series are cost-effective Brushless DC Planetary Gearmotors. These motors were designed keeping the OEM in mind, using state of the art design parameters and low-cost manufacturing. This allows us to offer there quality motors at exceptional prices. The BLWRPG17 Series include a planetary gearbox and a brushless DC motor in a compact fully integrated package. The brushless DC gearmotor is a perfect solution for applications requiring high torque or speeds under 500 RPM. These star wound motors come with integrated hall sensors for closed loop control for velocity applications. If the off-the-shelf gearmotors do not match your application, a motor can be wound or a gearbox can be selected to meet your specific requirements. We specialize in providing both off the self and custom solutions to handle any demanding application.

DIMENSIONS/SPECIFICATIONS

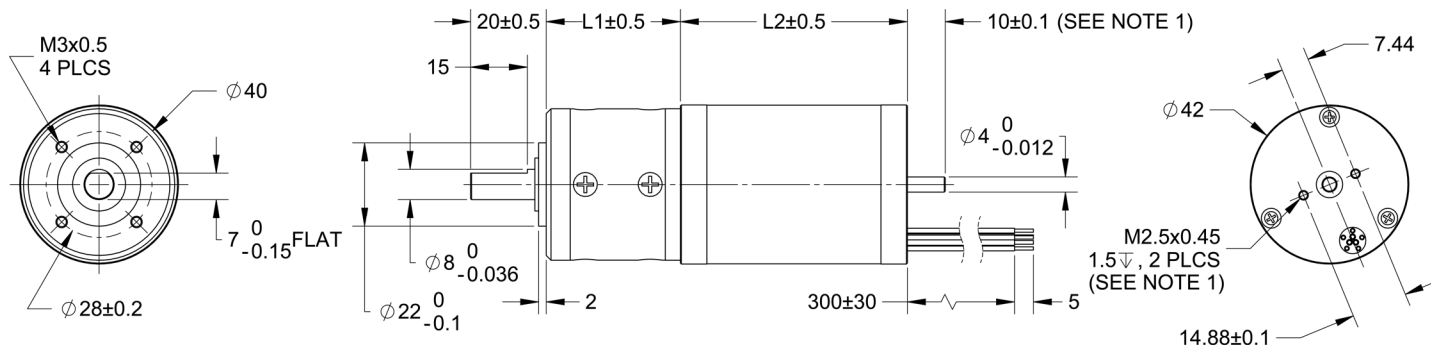

NOTE 1: Dual Shaft Version

Winding Type:	Star, 8 Poles	Planetary Gear Radial Play of Shaft:	0.04mm
Planetary Gear Housing:	Metal	Planetary Gear Thrust Play of Shaft:	0.3mm
Planetary Gear at Output:	Ball Bearings	Planetary Gear Shaft Press fit force, max:	331lbs
Planetary Gear Radial Load:	10mm @ 22lbs	Planetary Gear Shaft Axial Load:	6.6lbs

L010402

Wire Color	Description
Green	Phase A
Red	Phase B
Black	Phase C

Wire Color	Description
Yellow	Hall Vc
Blue	Hall A
Orange	Hall B
Brown	Hall C
White	Hall Ground

Hall Sensor Specifications
Supply Voltage: 4.5VDC to 28VDC
Current, I_{off} : 10mA max
Current, I_{on} : 11.3mA max
Rated Sinking Current: 20mA
Saturation Voltage: 0.4VDC max @ 25°C
Output Leakage Current: 10µA
Output Switching Time @ 25°C
Rise, 10% to 90% 1.5µs
Fall, 90% to 10% 1.5µs
Output Type: Open Collector

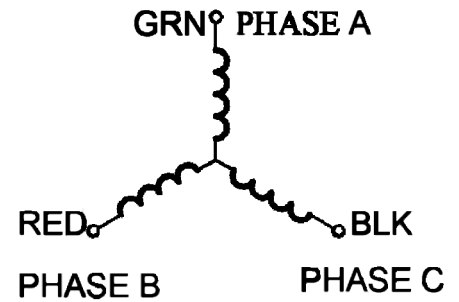

Create a complete Model Number by selecting a motor from Table 1 and Gear Box from Table 2

BLWRPG172S-24V-4200-R3.6

Table 1		Output on Shaft of Motor Before Gear-Box									
Model #	Rated Power (W)	Rated Current (A)	Line to Line Resistance (ohms)	Line to Line Inductance (mH)	Back EMF Voltage (V/kRPM)	Motor Weight (lbs)	Motor Length "L2" (mm)	Torque Constant (oz-in/A)	Rated Speed (RPM)	Rated Torque (oz-in)	Rotor Inertia (oz-in-sec ²)
BLWRPG172S-24V-1400	5.8	1.5	11.9	15	8.45	0.88	60	14.92	1400	5.66	0.00046
BLWRPG172S-24V-2100	11	2.6	5.8	6.28	7.17	0.76	60	9.70	2100	7.08	0.00046
BLWRPG172S-24V-4200	24	1.5	1.6	1.94	4.44	0.76	60	5.45	4200	7.93	0.00046
BLWRPG173S-24V-2000	31	2.1	2.18	2.96	5.40	0.88	85	9.88	2000	21.24	0.00082
BLWRPG173S-24V-4000	63	4.1	0.71	0.86	4.00	1.18	85	5.21	4000	21.24	0.00082

Table 2		Output on Shaft of Gearbox								
Parameters/Gear Box Ratio	3.8	4.9	15	19	24	56	71	91	116	212
Peak Torque (oz-in)	208	208	833	833	833	2083	2083	2083	2083	2083
Number of Gear Trains	1	1	2	2	2	3	3	3	3	4
"L1" (Length of Gear Box In millimeters)	35.0	35.0	45.5	45.5	45.5	55.5	55.5	55.5	55.5	66

* Weight will vary based on gear ratio selected.

** Length of gearmotor will vary based on gear ratio selected.

Notes: Custom leadwires, cables, connectors, and windings are available upon request.

- Rated Speed of the output shaft (after gear-box) = (Rated Motor Speed)/(Gear Ratio)
- Torque of the output shaft (after gear-box) = (Peak Motor Torque) X (Gear Ratio)
- Rotor Inertia of the output (shaft after gear-box) = (Rotor Motor Inertia) X (Gear Ratio)²